

WHEEL ALIGNMENT SPECIFICATIONS & PROCEDURES

1988 Jeep Cherokee

1988 Wheel Alignment
INTRODUCTION

PRE-ALIGNMENT

VEHICLE CHECKS

Prior to making wheel alignment adjustments, check and adjust the following items:

- 1) Tire pressure must be inflated to manufacturers recommended specifications. Tires should be equal in size and type. Runout must not be excessive. Tires and wheels should be in balance.
- 2) Wheel bearings must be properly adjusted. Steering linkage and suspension must not have excessive wear and/or looseness. Check for wear in tie rod ends and ball joints.
- 3) Steering gear box must not have excessive play. Check and adjust to manufacturer's specifications.
- 4) Vehicle must be at correct ride height with full fuel load and spare tire in vehicle. No extra load should be on vehicle.
- 5) Vehicle must be level with floor and with suspension settled. Jounce front and rear of vehicle several times and allow it to settle to normal ride height.
- 6) Ensure steering wheel spokes are centered with front wheels in straight-ahead position, correct by shortening one tie rod adjusting sleeve and lengthening opposite sleeve equal amounts.
- 7) Ensure wheel lug nuts are tightened to torque specifications.

DESCRIPTION

CAMBER

Camber is the inward or outward tilt of the wheel as viewed from front of vehicle. Camber is measured from centerline of vehicle. When wheel is tilted outward at top from centerline of vehicle, camber is positive. When wheel is tilted inward at top from centerline of vehicle, camber is negative. Camber is measured in degrees from vertical.

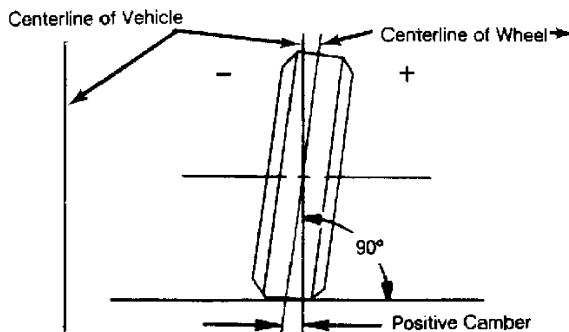

30409
Fig. 1: Camber Angle

CASTER

Caster is the tilting of front steering axis. This forward

or backward tilt from vertical is viewed from side of vehicle. When axis is tilted backward from vertical, caster is said to be positive, creating a trailing action on front wheels. When axis is tilted forward, caster is negative, causing a leading action on front wheels.

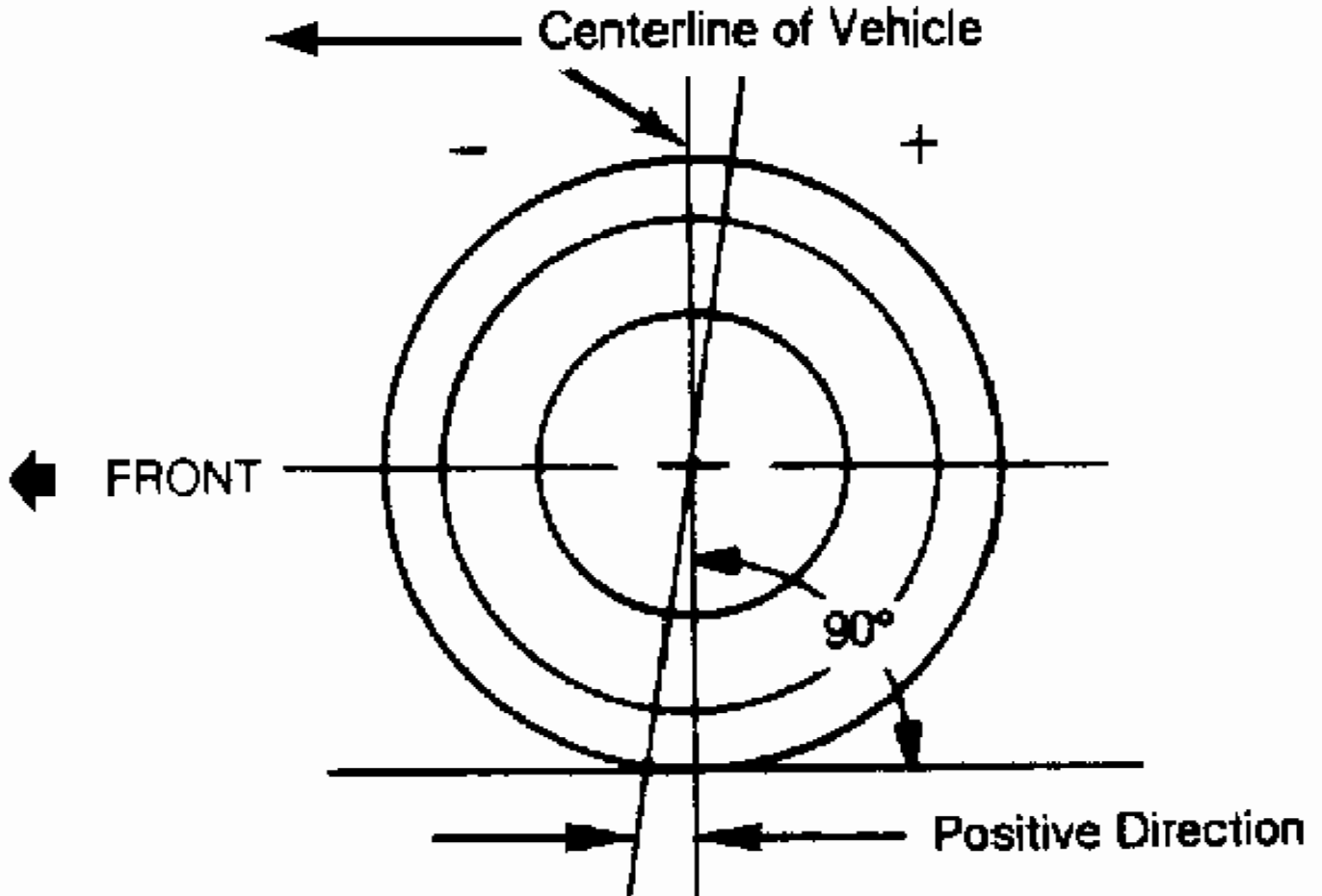

30410

Fig. 2: Caster Angle

TOE

Toe is the measured difference in inches of distance between the front edge of the tires and the rear edge of the tires at spindle height. Toe can be measured in inches or degrees.

ADJUSTMENT

TOE

1) Measure toe with front wheels straight-ahead and steering wheel locked in a centered position. Adjust toe by loosening clamps and adjusting sleeve or adjusting ends on right and left tie rods equally and in opposite directions to maintain steering wheel in centered position.

2) If steering wheel is not centered to begin with, determine which tire assembly is toed in or out more than the other

and compensate adjustment more to that side to center steering wheel. A couple of tries will probably be necessary to properly center steering wheel.

3) When tightening clamps, make sure that clamp bolts are positioned so there will be no interference with other parts throughout entire travel of steering linkage.

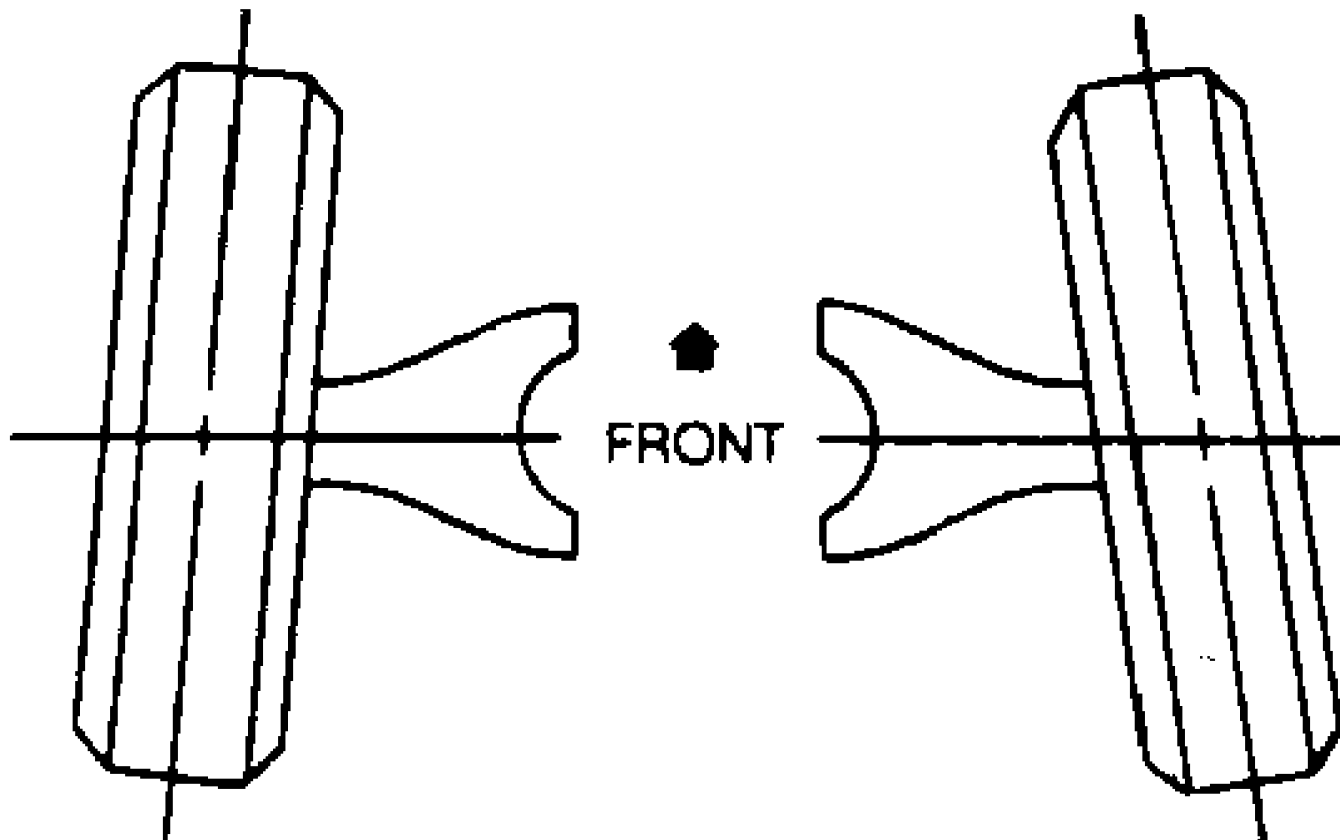

30412

Fig. 3: Wheel Toe

To adjust, turn sleeves an equal amount in opposite directions.

TOE-OUT ON TURNS

1) This is a check for bent or damaged parts, and not a service adjustment. With caster, camber and toe-in properly adjusted, check toe-out with weight of vehicle on wheels.

2) Use full-floating turn table under each wheel. Turn left wheel in 20 degrees on scale of turn table and read scale of turn table on right wheel. Reading should be within 2 degrees of left wheel. Repeat test for right wheel.

3) Incorrect readings of toe-out generally indicates a bent steering arm. Replace arm and recheck wheel alignment adjustments. Do not attempt to correct by straightening parts.

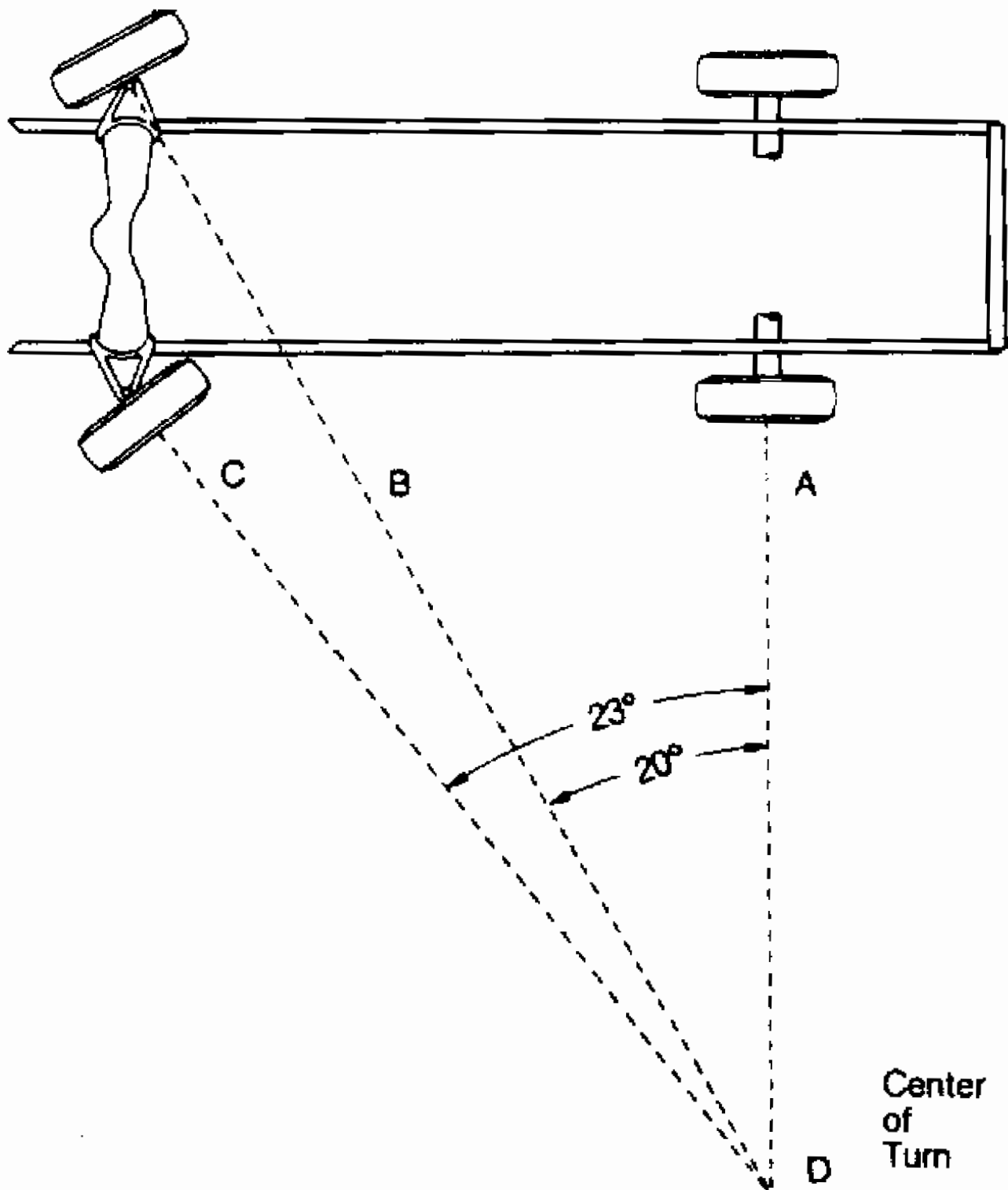

30413

Fig. 4: Wheel Toe-Out on Turns

STEERING AXIS INCLINATION

1) This is a check for bent or damaged parts, and not a

service adjustment. Vehicle must be level, both crosswise and lengthwise. Camber should be properly adjusted.

2) If camber cannot be brought within limits and steering axis inclination is correct, steering knuckle is bent. If camber and steering axis inclination are both incorrect by approximately the same amount, upper and lower control arms are bent.

3) Replace parts and recheck all wheel alignment adjustments. Do not attempt to correct by straightening parts.

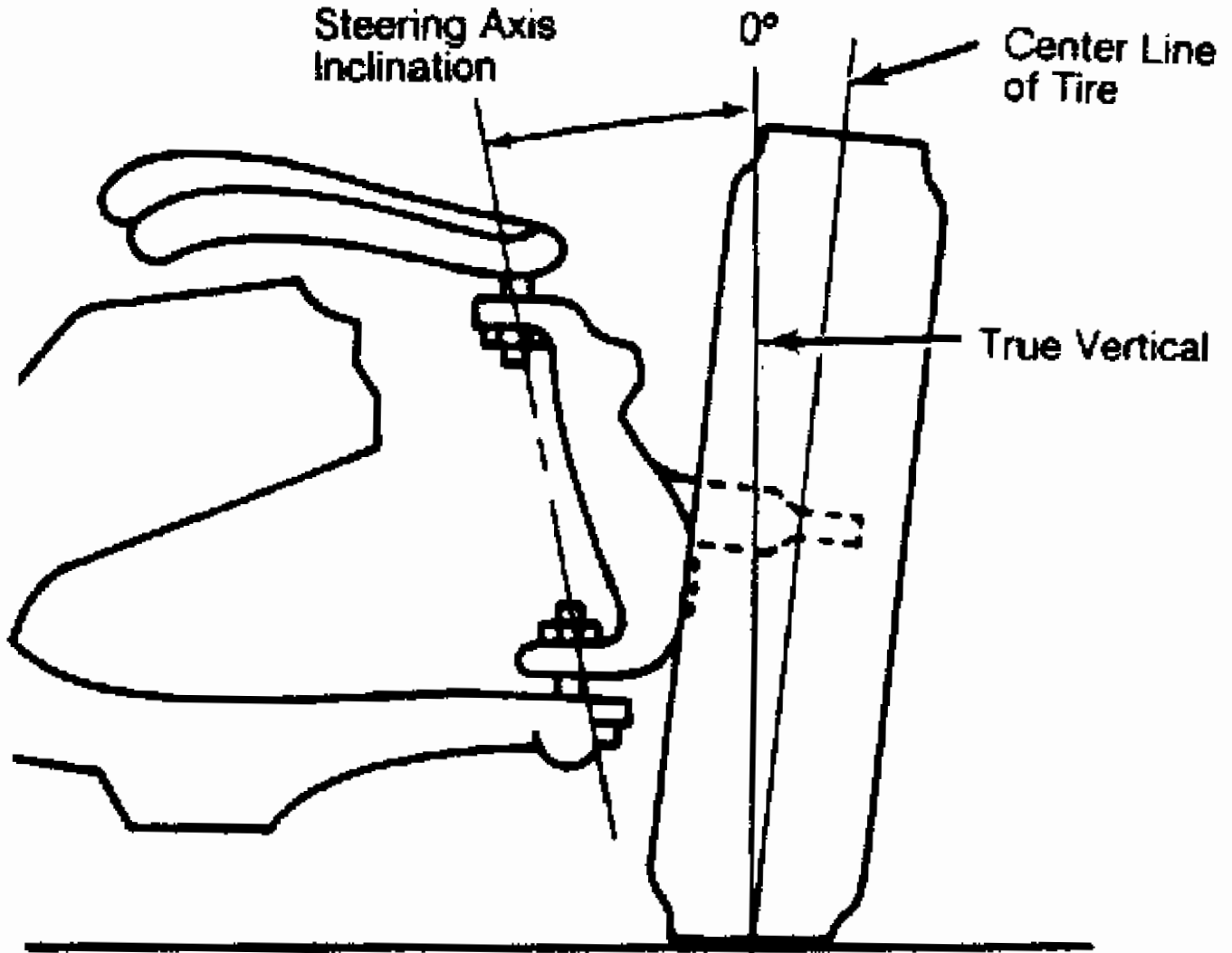

30414

Fig. 5: Steering Axis Inclination

TORQUE SPECIFICATIONS

WHEEL LUG NUT TORQUE SPECIFICATIONS TABLE

Application	Ft. Lbs. (N.m)
Grand Wagoneer	85 (115)
All Other Models	75 (102)

ALIGNMENT SPECIFICATIONS

WHEEL ALIGNMENT SPECIFICATIONS TABLE

Application	Specification
Cherokee, Comanche, Wrangler & Wagoneer	
Ride Height in Inches
Adjustment Procedures
Camber in Degrees (Fraction)	-1/2 to 1/2
Camber in Degrees (Decimal)	-0.50 to 0.50
Caster in Degrees (Fraction)	7 to 8
Caster in Degrees (Decimal)	7.0 to 8.0
Toe-In in Inches (Fraction)	1/32 to 1/32
Toe-In in Inches (Decimal)	0.031 to 0.031
Toe-In in Degrees (Fraction)	1/16 to 1/16
Toe-In in Degrees (Decimal)	0.063 to 0.063
Toe-Out on Turns	
Inner	NS
Outer	NS
Steering Axis Inclination (SAI)	8 1/2 °
Grand Wagoneer	
Ride Height in Inches
Adjustment Procedures
Camber in Degrees (Fraction)	0 to 1/2
Camber in Degrees (Decimal)	0 to 0.5
Caster in Degrees (Fraction)	4 to 5
Caster in Degrees (Decimal)	4.0 to 5.0
Toe-In in Inches (Fraction)	3/64 to 3/32
Toe-In in Inches (Decimal)	0.047 to 0.094
Toe-In in Degrees (Fraction)	3/32 to 3/16
Toe-In in Degrees (Decimal)	0.094 to 0.188
Toe-Out on Turns	
Inner	NS
Outer	NS
Steering Axis Inclination (SAI)	8 1/2 °

NS - Information not available from manufacturer.

RIDING HEIGHT SPECIFICATIONS

Inflate tires to proper air pressure. Specifications can be found on door pillar or in glove box. Cargo compartment must be empty. Fuel tank should be full. Bounce vehicle up and down to normalize ride height. Ride height specifications in regard to setting camber and caster are not provided by the manufacturer.